

CHOLET DECK MOUNT COMMERCIAL BRUSHED NICKEL AUTOMATIC SENSOR FAUCET SPECS

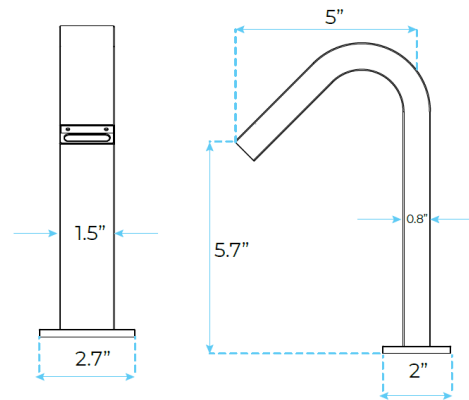

Specs:

- Power: DC:6V(4AA alkaline battery)
- AC:220V-240V; 50/60HZ
- Water pressure: 0.05~0.86 MPa
- Detection Zone: Automatic adjustment
- Motor valve lifespan: up to 500000 flushes
- Battery lifespan: 100000 cycles
- Static Power Consumption: 0.36mw
- Working Power consumption: 0.5mw
- Sensor Duration: Less than 0.5s
- Shut-off Delay: 0.5~1 s
- Dia.of inlet / outlet pipe: G1/2"
- Flux: $\geq 0.07L/S$
- Temperature: 0.1-50°C
- Flow Rate: No more than 2.0L/min at 0.3 MPa.

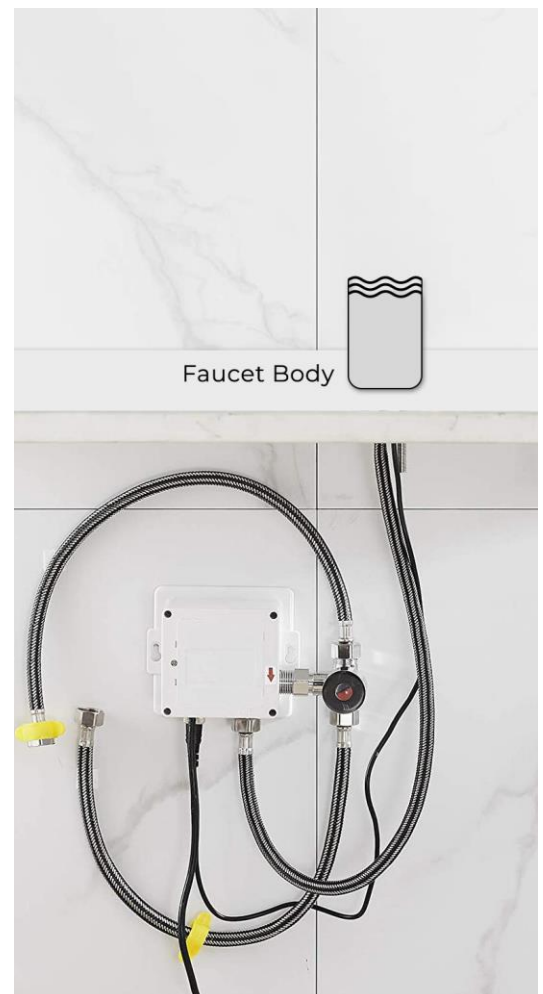

Other Details

[Visit Product page](#)